



SERIES AZ 1400T

TIED DIAPHRAGM REGULATOR

Intermediate to high flow applications

- Single stage
- SS 316L construction
- Absolute sub-atmospheric option, flow rate to 6 slpm
- Cylinder or point of use specialty and bulk gases
- Flow rates to 600 slpm (21 scfm)
- Vacuum to 2,300 psig (159 bar) inlet
HR option to 3,000 psig (207 bar)
- Knob LOTO (refer to AP KL data sheet)
- Installation and operating instructions available at www.aptech-online.com in the Tech Briefs section

Operating Parameters

Source pressure	AZ 1400T	vacuum to 2,300 psig (159 bar)
	AZ 1400TA	vacuum to 300 psig (21 bar)
	AZ 1400T HR	vacuum to 3,000 psig (207 bar)
Delivery pressure	AZ 1402TA	100 mm Hg absolute to 30 psig (2 bar) (not available for HR)
	AZ 1402T	1 to 30 psig (0.07 to 2 bar) (not available for HR)
	AZ 1406T	1 to 60 psig (0.07 to 4 bar) (not available for HR)
	AZ 1410T	2 to 100 psig (0.14 to 7 bar)
	AZ 1415T*	5 to 150 psig (0.34 to 10 bar)
Proof pressure		150% of operating pressures
Burst pressure		300% of operating pressures

*AZ 1415T will not achieve full outlet pressure rating at all inlet pressures.

Other Parameters

Inlet/outlet connectors	1/4, 3/8 or 1/2 inch face seal or tube weld
Flow coefficient (Cv)**	0.5
Internal volume	1.06 in ³ (17.4 cm ³)
Operating temperature	-40° to +160°F (-40° to +71°C)**
Surface finish	10 µin. (0.25 µm) Ra avg. standard 25 µin. (0.62 µm) Ra avg. optional
Inboard leakage	2 x 10 ⁻¹⁰ sccs
Outboard leakage	2 x 10 ⁻⁹ sccs He
Leakage across seat	4 x 10 ⁻⁸ sccs He
Installation	surface or panel (optional)
Supply pressure effect	1.6 psig per 100 psig source pressure change

**VS option 14° to 194°F (-10° to + 90°C).

***A pressure regulator Cv is a nominal value which indicates the point of choked flow. Please refer to a flow curve or a recommendation guide for usable flow range.

Materials

Series AZ 1400T S	
Wetted Parts	
Body, nozzle	stainless steel 316L***
Diaphragm, poppet	Ni-Cr-Mo alloy / UNS N06022
Finish	electropolished and passivated
Seat	PCTFE (Polyimide optional)

***Please refer to product note PN 414 regarding single melt 316L SS material.

All specifications subject to change without notice.

ULTRACLEAN BY DESIGN

DIMENSIONAL INFORMATION

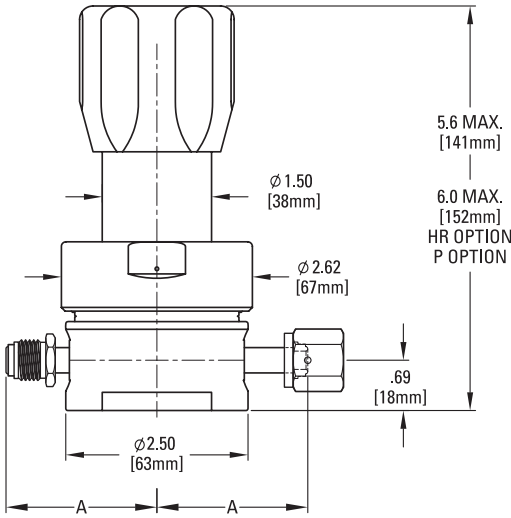

All dimensions in inches. Metric dimensions (mm) are for reference only.

Face Seal	A	
	in	mm
1/4"	2.15 ±.01	55
3/8", 1/2"	2.61 ±.02	66

PORTING CONFIGURATIONS

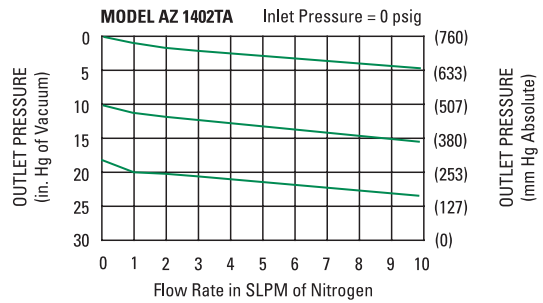
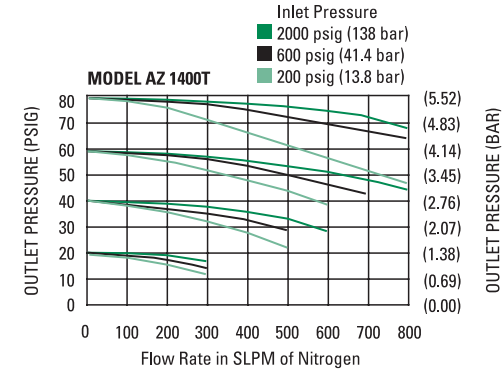
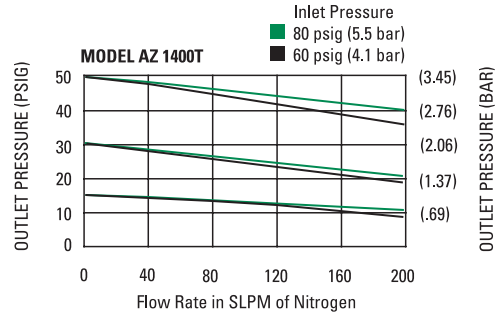
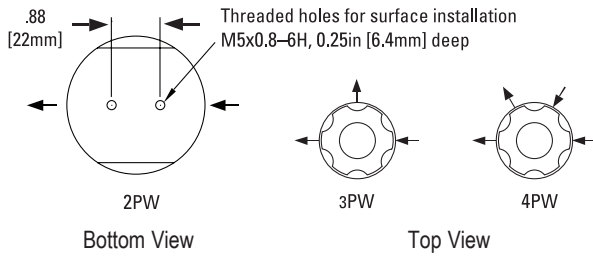

CAUTION: Product selection is the sole responsibility of the user, regardless of any recommendations or suggestions made by the factory. The user shall make selections based upon their own analysis and testing with regard to function, material compatibility and product ratings. Proper installation, operation and maintenance are also required to assure safe, trouble free performance.

ORDERING INFORMATION

Sample Order Number **AZ 1402TSA 3PW FV4 FV4 V3**

AZ 1402T Series	AZ 1402T = 1-30 psig (.07 to 2 bar) AZ 1406T = 1-60 psig (.07 to 4 bar) AZ 1410T = 2-100 psig (.14 to 7 bar) AZ 1415T = 5-150 psig (.35 to 10 bar)
S Material	S = Stainless steel (SHP)* <small>*S equivalent to SHP – stainless steel with Ni-Cr-Mo alloy poppet and diaphragm</small>
Q Surface Finish Option	Q = 25 µin. Ra avg.
A Range Options	A = 100 mm Hg absolute to 30 psig (2 bar) (AP 1402T option only)
3PW Ports	2PW = 2 ports butt weld 3PW = 3 ports butt weld 4PW = 4 ports butt weld

FV4 FV4 Connections Inlet / Outlet	FV4 = 1/4 inch face seal female MV4 = 1/4 inch face seal male FV6 = 3/8 inch face seal female MV6 = 3/8 inch face seal male FV8 = 1/2 inch face seal female MV8 = 1/2 inch face seal male Tube weld stub available
---	--

V3 Gauges** Source / Delivery	0 = No gauge V3 = 30-0-30 psig/bar L = 30-0-60 psig/bar 1 = 30-0-100 psig/bar 2 = 0-200 psig/bar 4 = 0-400 psig/bar 10 = 0-1000 psig/bar 40 = 0-4000 psig/bar
--	--

**Standard gauge ports are 1/4 inch face seal male (1/4 inch face seal female are available).

Options

VS = Polyimide seat
HR = High inlet pressure
P = Panel installation***
KL = Knob LOTO (refer to AP KL data sheet)

***Panel hole 1.56" diameter.

AP Tech has product options and variations which are not documented in data sheets. If you have a model number that is not defined by the ordering information, please consult the factory or your local representative.