

# SERIES AK 14PAT TIED DIAPHRAGM REGULATOR PNEUMATIC ACTUATION



- ◆ **Flow capacity<sup>‡</sup>**  
200 sccm to 400 slpm
- ◆ **Actuation control pressure isolated**  
**from process gas**
- ◆ **Vacuum to 2,300 psig (159 bar) inlet,**  
**7 (0.5 bar) to 150 psig (10 bar) outlet**
- ◆ **Stainless Steel or Brass construction**
- ◆ **Poppet attached to diaphragm**  
**(tied diaphragm) improves positive shut**  
**off across the seat**
- ◆ **Machined from bar stock**
- ◆ **100 psig outlet achieved with 80 psig**  
**control pressure or less**
- ◆ **Ni-Cr-Mo alloy internals, 'SH' option,**  
**for added corrosion resistance**
- ◆ **Cleaned for O2 service**
- ◆ **Field repairable**
- ◆ **Actuation 'fail safe' normally closed (NC)**
- ◆ **Installation and operating instructions**  
**available at [www.aptech-online.com](http://www.aptech-online.com) in**  
**the Tech Briefs section**

## ENGINEERING DATA

### Operating Parameters

Source pressure	vacuum to 2,300 psig (159 bar)
	HR option vacuum to 3,000 psig (207 bar)*
AK 14PATA	vacuum to 300 psig (21 bar)
Delivery pressure	7 to 150 psig (0.5 to 10 bar)
AK 14PATA	100 mm Hg to 30 psig ( 2 bar)
Proof pressure	150% of operating pressures)
Burst pressure	300% of operating pressures
Control pressure	150 psig (10 bar) maximum

### Other Parameters

Inlet /outlet ports	1/4", 3/8" and 1/2" NPT and compression (optional porting available)
Control pressure port	1/8 inch NPT
Bonnet vent port	1/8 inch NPT
Flow coefficient, Cv <sup>††</sup>	0.45
Internal volume	1.14 in <sup>3</sup> (18.7 cm <sup>3</sup> )
Operating temperature	-40° to +160°F (-40° to +71°C)**
Leak rate	1 x 10 <sup>-9</sup> sccs
Supply pressure effect	1.6 psig per 100 psig source pressure change

## MATERIALS OF CONSTRUCTION

	AK 14PATB	AK 14PATS	AK 14PATSH
Body	brass	SS 316L	SS 316L
Diaphragm	Ni-Cr-Mo alloy / UNS N06022	Ni-Cr-Mo alloy / UNS N06022	Ni-Cr-Mo alloy / UNS N06022
Nozzle	SS 316	SS 316	Ni-Cr-Mo alloy / UNS N06022
Poppet	Ni-Cr-Mo alloy / UNS N06022	Ni-Cr-Mo alloy / UNS N06022	Ni-Cr-Mo alloy / UNS N06022
Seat	PCTFE***	PCTFE***	PCTFE

<sup>‡</sup>Flow rating based upon N2 @ 100 psig inlet, varying gas type and, or inlet/outlet pressures may effect rating.

<sup>††</sup>A pressure regulator Cv is a nominal value which indicates the point of choked flow. Please refer to a flow curve or a recommendation guide for usable flow range.

\*HR option may not achieve rated outlet pressure at all inlet pressures.

\*\*VS option 14° to 194°F (-10° to +90°C).

\*\*\*Optional seat materials available, Polyimide.

All specifications subject to change without notice.

# UNCOMPROMISING QUALITY, RELIABILITY & PERFORMANCE FROM A COMPANY KNOWN FOR SERVICE

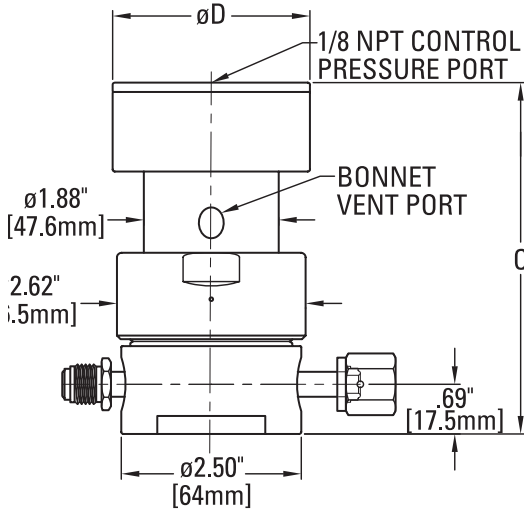

	C		D	
14PA	4.9MAX	124	2.74	69.6
14PATA	4.7MAX	119	1.87	47.5

All dimensions in inches (mm). Metric dimensions are for reference only.  
All specifications subject to change without notice.

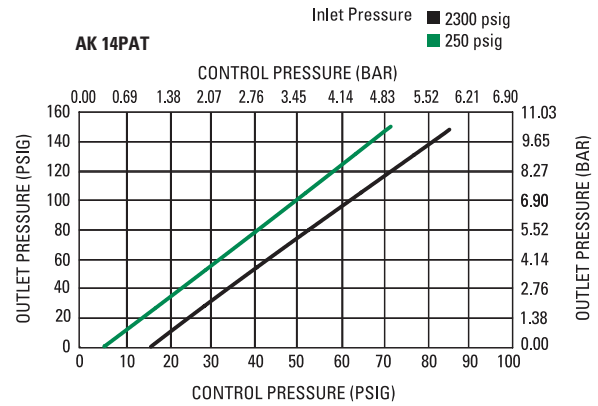
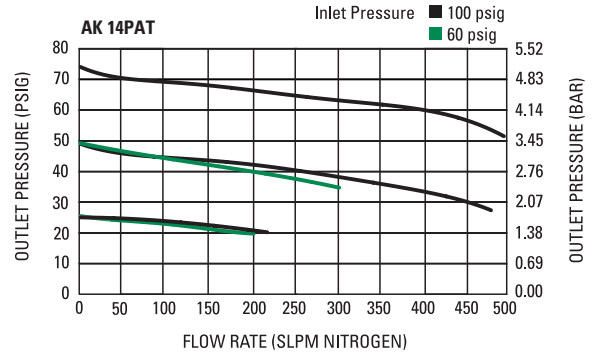

## Porting Configurations

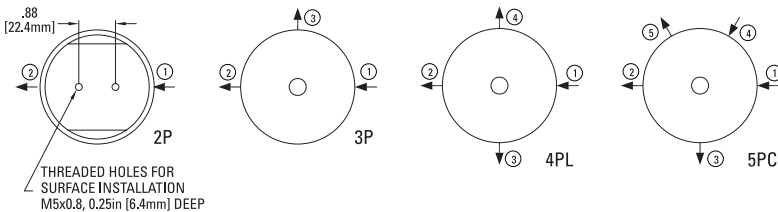

**NOTE:** Brass only available with 4PL or 5PC porting.  
Ports, other than 1 & 2, are only available 1/4 inch NPT.

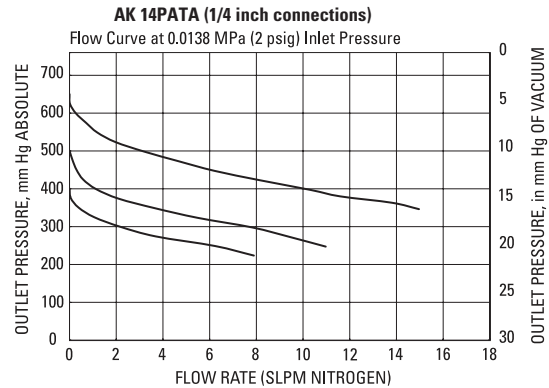

**CAUTION:** Product selection is the sole responsibility of the user, regardless of any recommendations or suggestions made by the factory. The user shall make selections based upon their own analysis and testing with regard to function, material compatibility and product ratings. Proper installation, operation and maintenance are also required to assure safe, trouble free performance.

## ORDERING INFORMATION

AK 14PAT Series	S Material	A Range Option	3P Ports	6 6 Connections Inlet / Outlet	1 Ports (Gauge/Accessory)	Options
AK 14PAT = 7-150 psig (0.5 to 10 bar)	S = Stainless steel (SS) SH = SS with Ni-Cr-Mo alloy internals B = Brass	A = 100mm Hg absolute to 30 psig (2 bar)	2P = 2 Ports 3P = 3 Ports 4PL = 4 Ports 5PC = 5 Ports	① ② 4 = 1/4 inch NPT 6 = 3/8 inch NPT 8 = 1/2 inch NPT 4T = 1/4 inch comp. 6T = 3/8 inch comp. 8T = 1/2 inch comp.	③ ④ ⑤ 0 = No gauge V3 = 30-0-30 psig/bar 1 = 30-0-100 psig/bar 2 = 0-200 psig/bar 10 = 0-1000 psig/bar 40 = 0-4000 psig/bar	VS = Polyimide seat HR = High inlet pressure*  *Full rated outlet pressure may not be achieved at all inlet pressures.

**NOTE:** Designators required for all ports, but "0" not required if there isn't a port. A 2P has designators only for 1 & 2 ports, as example AK 14PAT S 2P 44 not AK 14PAT S 2P 44 000.

AP Tech has product options and variations which are not documented in data sheets. If you have a model number that is not defined by the ordering information, please consult the factory or your local representative.