



ADVANCED PRESSURE TECHNOLOGY

SERIES AK M80 CROSSOVER MANIFOLD ASSURES CONTINUOUS GAS SUPPLY

- ◆ Automatically switches from one cylinder to another when the primary cylinder empties
- ◆ Allows changing of cylinders during operation
- ◆ Simple, worry free, pressure based system
- ◆ Vacuum to 3,500 psig (241 bar) inlet, 250 psig (17 bar) outlet
- ◆ Flow capacity* to 50 slpm (1.8 scfm)
- ◆ Stainless Steel or Brass construction
- ◆ Diffusion resistant 316 SS diaphragm
- ◆ Cleaned for O2 service
- ◆ Mounting bracket standard
- ◆ Two inlet and one outlet gauges standard
- ◆ Installation and operating instructions available at www.aptech-online.com in the Tech Briefs section



ENGINEERING DATA

Operating Parameters

Source pressure	Vacuum to 3,500 psig (241 bar)
Delivery pressure	
M80 02	1 to 30 psig (0.07 to 2 bar)
M80 10	10 to 100 psig (0.7 to 7 bar)
M80 15	15 to 150 psig (1 to 10 bar)
M80 25	25 to 250 psig (1.7 to 17 bar)
Proof pressure	150% of operating pressures
Burst pressure	300% of operating pressures

Other Parameters

Inlet /outlet ports	1/4" NPT
Flow coefficient, Cv [‡]	0.05
Operating temperature	-40° to +160°F (-40° to +71°C)**
Leak rate	1 x 10 ⁻⁹ sccs
Supply pressure effect	0.05 psig per 100 psig source pressure change
Weight	9.1 lb

MATERIALS OF CONSTRUCTION

	AK M80 B	AK M80 S	AK M80 SH
Body	brass	SS 316L	SS 316L
Poppet and diaphragm	SS 316	SS 316	Ni-Cr-Mo alloy / UNS N06022
Seat	PCTFE***	PCTFE***	PCTFE***
Bonnet	SS 303	SS 303	SS 303

*Flow rating based upon N2 @ 200 psig inlet, varying gas type and, or inlet/outlet pressures may effect rating.

**VS option 14° to 194°F (-10° to +90°C).

***Optional seat materials available, Polyimide and PEEK.

‡A pressure regulator Cv is a nominal value which indicates the point of choked flow. Please refer to a flow curve or a recommendation guide for usable flow range.
All specifications subject to change without notice.

M80 ASSURES PEACE OF MIND THROUGH CONSTANT GAS DELIVERY

Operations Overview

The M80 crossover manifold system is comprised of three pressure regulators – two separate first stage regulators housed in a common body and a second stage regulator. The two first stage regulators are each attached to separate source cylinders. The second stage is attached to a common outlet of the two first stage regulators. One of the first stage regulators has an adjustment knob that rotates 270 degrees to enable source side selection. The other first stage is preset to an appropriate setting for the system outlet range. The source selection knob adjusts the intermediate outlet pressure to be either 15 psig above or below the preset side. An arrow on the selection knob points to the cylinder side delivering gas and away from the standby cylinder. The intermediate outlet pressure of the first stage delivery side is approximately 15 psig (1 bar) higher than the standby side. Rotating the knob to point to the standby side, changes the pressure differential such that the standby side now becomes the delivery side. The process delivery pressure outlet is adjusted with the knob of the second stage regulator.

As the delivery side cylinder becomes empty and the pressure drops below the pressure of the standby side, gas begins to flow from the standby side. The source selection knob is then turned to what was the standby side and the empty cylinder may now be replaced without interrupting process flow.

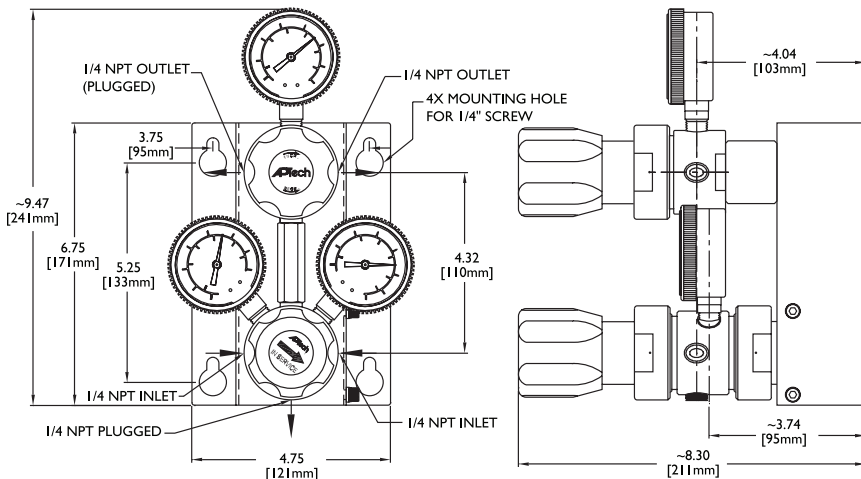

CAUTION: Product selection is the sole responsibility of the user, regardless of any recommendations or suggestions made by the factory. The user shall make selections based upon their own analysis and testing with regard to function, material compatibility and product ratings. Proper installation, operation and maintenance are also required to assure safe, trouble free performance.

***Exceeding 50 slpm N2 may cause gas to be drawn from both A & B sides at the same time.**

All dimensions in inches [mm]. Metric dimensions are for reference only.

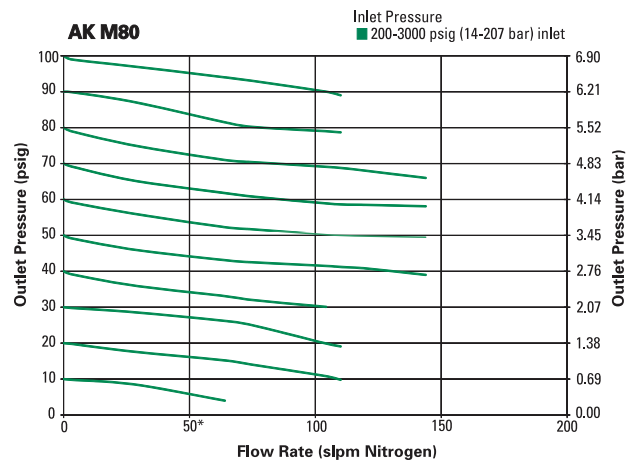
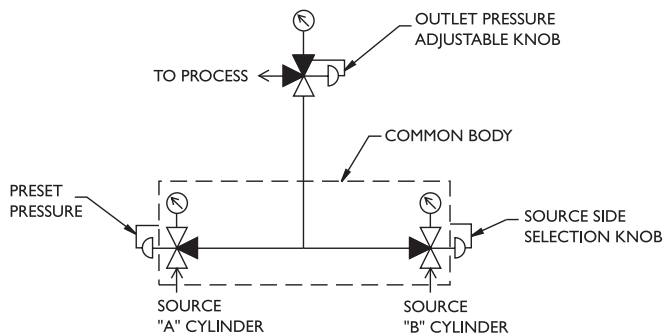

ORDERING INFORMATION

Series AK M80 10	S Material	40 Inlet Gauges	VS Options
AK M80 02 = 1 - 30 psig (.07 to 2 bar) AK M80 10 = 2 - 100 psig (.7 to 7 bar) AK M80 15 = 15 - 150 psig (1 to 10 bar) AK M80 25 = 25 - 250 psig (1.7 to 17 bar)	S = Stainless steel 316 (SS) SH = SS with Ni-Cr-Mo alloy internals B = Brass	4 = 0-400 psig 6 = 0-600 psig 10 = 0-1,000 psig 20 = 0-2,000 psig 30 = 0-3,000 psig 40 = 0-4,000 psig Outlet Gauge, will be supplied to match outlet range, do not specify in part number	PK = PEEK seat VS = Polyimide seat

AP Tech has product options and variations which are not documented in data sheets. If you have a model number that is not defined by the ordering information, please consult the factory or your local representative.