



# SERIES AP 10PA

## PNEUMATICALLY ACTUATED PRESSURE REGULATOR

Low Flow — High Pressure

- Actuation control pressure isolated from process gas by two seals
- Single stage
- SS 316L VAR secondary remelt or super alloy construction
- Cleaned, assembled and packaged for high purity semiconductor applications
- Surface finish  
15 Ra max/10 Ra avg  
(10, 7 & 5 Ra max options)
- Vacuum to 3,500 psig (241 bar) inlet
- 100 psig outlet achieved with 80 psig control pressure or less
- Actuator 'fail safe' normally closed (NC)
- Installation and operating instructions available at [www.aptech-online.com](http://www.aptech-online.com)

### Operating Parameters

Source pressure		vacuum to 3,500 psig (241 bar)
Delivery pressure	AP 10PA	7 to 150 psig (0.5 to 10 bar)
Proof pressure		150% of operating pressures
Burst pressure		300% of operating pressures
Control pressure		150 psig (10 bar) maximum

### Other Parameters

Inlet/outlet connectors	1/4 or 3/8 inch face seal or tube weld
Control pressure port	1/8 inch NPT
Bonnet vent port	1/8 inch NPT
Flow coefficient (Cv)***	0.09 (0.15 HF option)
Internal volume	0.49 in <sup>3</sup> (8 cm <sup>3</sup> )
Operating temperature	-40° to +160°F (-40° to +71°C)*
Surface finish	15 µin Ra max / 10 µin. Ra avg. (0.4/0.25 µm) standard; 10 µin (0.25 µm); 7 µin (0.18 µm); and 5 µin (0.13 µm) Ra max optional Optional surface finishes meet or exceed 5 µin Ra average
Inboard leakage	2 x 10 <sup>-10</sup> sccs
Outboard leakage	2 x 10 <sup>-9</sup> sccs He at 1,500 psig inlet pressure
Leakage across seat	4 x 10 <sup>-8</sup> sccs He at 1,000 psig inlet pressure
Installation	surface
Supply pressure effect	0.25 psig per 100 psig source pressure change
HF	0.75 psig per 100 psig source pressure change

\*VS option 14° to 194°F (-10° to +90°C).

\*\*\*A pressure regulator Cv is a nominal value which indicates the point of choked flow. Please refer to a flow curve or a recommendation guide for usable flow range.

### Materials

Type of Service	Series AP 10PA S Noncorrosive	Series AP 10PA SH Corrosive (SHP option)**	Series AP 10PA H Corrosive
Wetted Parts			
Body	SS 316L secondary remelt	SS 316L secondary remelt	Ni-Cr-Mo alloy / UNS N06022
Poppet, nozzle, diaphragm	SS 316L	Ni-Cr-Mo alloy / UNS N06022	Ni-Cr-Mo alloy / UNS N06022
Finish	electropolished and passivated	electropolished and passivated	electropolished
Seat	PCTFE (Polyimide optional)	PCTFE	PCTFE

\*\*SHP option Ni-Cr-Mo alloy poppet and diaphragm only.  
All specifications subject to change without notice.

# ULTRACLEAN TECHNOLOGY BACKED BY SERVICE AND SUPPORT

## DIMENSIONAL INFORMATION

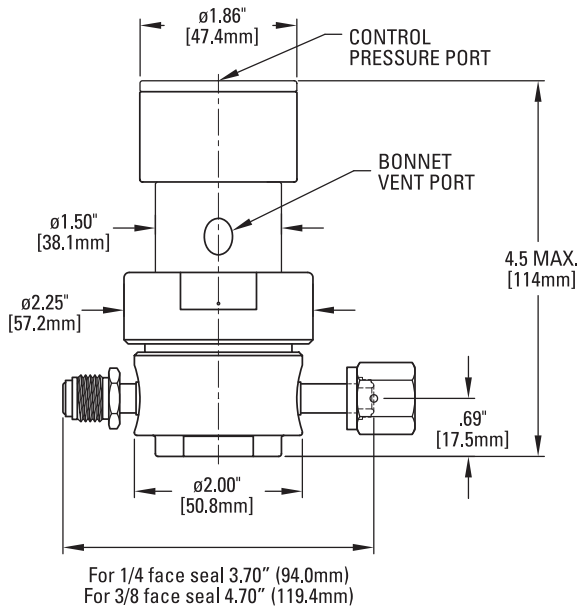

All dimensions in inches (mm). Metric dimensions are for reference only.

## PORTING CONFIGURATIONS

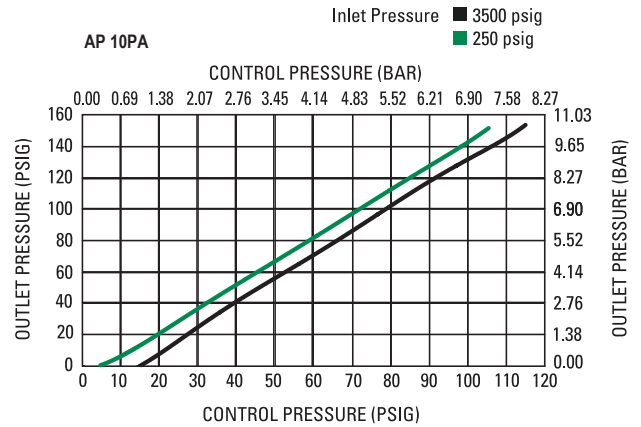
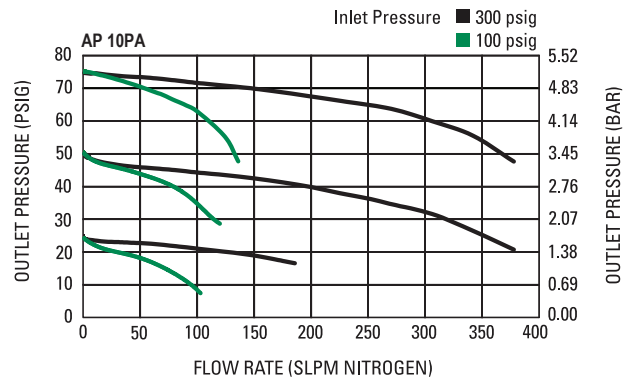
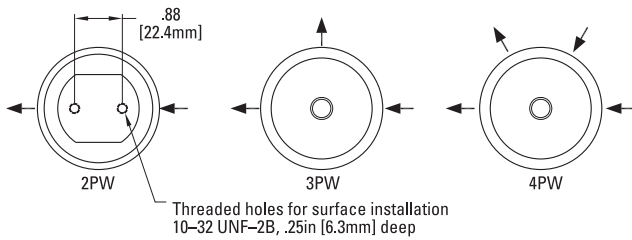

**CAUTION:** Product selection is the sole responsibility of the user, regardless of any recommendations or suggestions made by the factory. The user shall make selections based upon their own analysis and testing with regard to function, material compatibility and product ratings. Proper installation, operation and maintenance are also required to assure safe, trouble free performance.

## ORDERING INFORMATION

Sample Order Number: AP 10PASM 4PW FV4 FV4 40 1

**AP 10PA | Series** AP 10PA = 7-150 psig (.5 to 10 bar)

**S | Material**

- S = Stainless steel (SS)
- SH = SS/Ni-Cr-Mo alloy internals
- SHP = SS/Ni-Cr-Mo alloy poppet diaphragm
- H = Ni-Cr-Mo alloy

**M | Surface Finish Options**

- M = 10  $\mu$ in. Ra max
- V = 7  $\mu$ in. Ra max
- X = 5  $\mu$ in. Ra max

**4PW | Ports**

- 2PW = 2 ports butt weld
- 3PW = 3 ports butt weld
- 4PW = 4 ports butt weld

**FV4 FV4 | Connections Inlet / Outlet**

FV4 = 1/4 inch face seal female  
 MV4 = 1/4 inch face seal male  
 FV6 = 3/8 inch face seal female  
 MV6 = 3/8 inch face seal male

Tube weld stub available

**40 1 | Gauges\* Source / Delivery**

0 = No gauge  
 V3 = 30-0-30 psig/bar  
 L = 30-0-60 psig/bar  
 1 = 30-0-100 psig/bar  
 2 = 0-200 psig/bar  
 4 = 0-400 psig/bar  
 10 = 0-1000 psig/bar  
 40 = 0-4000 psig/bar

\* Standard gauge ports are 1/4 inch face seal male (1/4 inch female available).

**Options**

VS = Polyimide seat  
 HF = High flow  
 SC = Short bonnet

AP Tech has product options and variations which are not documented in data sheets. If you have a model number that is not defined by the ordering information, please consult the factory or your local representative.