



SERIES AP 12PA

TIED DIAPHRAGM REGULATOR

PNEUMATIC ACTUATION

High Performance — High Flow – High Pressure

- 100 psig outlet achieved with 80 psig control pressure or less
- Actuation control pressure isolated from process gas
- Stainless steel 316L VAR secondary remelt construction
- Flow rates
 - standard to 800 slpm (28 scfm)
 - HF option to 1,000 slpm (35 scfm)
- Vacuum to 1,700 psig (117 bar) inlet HR Option – vacuum to 3,000 psig (207 bar) inlet
- Point of use and source cylinder applications
- Actuation “fail safe” normally closed (NC)
- Installation and operating instructions available at www.aptech-online.com in the Tech Briefs section

Operating Parameters

Source pressure	AP 12PA	vacuum to 1,700 psig (117 bar)
	AP 12PA HR	vacuum to 3,000 psig (207 bar)
Delivery pressure	AP 12PA	7 to 150 psig (0.5 to 10 bar)
Proof pressure		150% of operating pressures
Burst pressure		300% of operating pressures
Control pressure		150 psig (10 bar) maximum

Other Parameters

Inlet/outlet connectors	1/4, 3/8, 1/2, 3/4 inch face seal or tube weld
Bonnet vent port	1/8 inch NPT
Control pressure port	1/8 inch NPT
Flow coefficient (Cv)***	0.9 (HF = 1.1)**
Internal volume	1.20 in ³ (19.6 cm ³)
Operating temperature	-40° to +160°F (-40° to +71°C)*
Surface finish	15 µin Ra max / 10 µin. Ra avg. (0.4/0.25 µm) standard; 10 µin (0.25 µm); 7 µin (0.18 µm); and 5 µin (0.13 µm) Ra max optional Optional surface finishes meet or exceed 5 µin Ra average
Inboard leakage	2 x 10 ⁻¹⁰ sccs
Outboard leakage	2 x 10 ⁻⁹ sccs He at 1,500 psig inlet pressure
Leakage across seat	4 x 10 ⁻⁸ sccs He at 1,000 psig inlet pressure
Installation	surface
Supply pressure effect	3.5 psig per 100 psig source pressure change
	HF 4.2 psig per 100 psig source pressure change

*VS option 14° to 194°F (-10° to + 90°C).

***A pressure regulator Cv is a nominal value which indicates the point of choked flow. Please refer to a flow curve or a recommendation guide for usable flow range.

Materials

	Series AP 12PA S	Series AP 12PA SH
Type of Service	Noncorrosive	Corrosive (SHP** opt)
Wetted Parts		
Body	SS 316L secondary remelt	SS 316L secondary remelt
Poppet, nozzle	SS 316L	Ni-Cr-Mo alloy / UNS N06022
Diaphragm	Ni-Cr-Mo alloy / UNS N06022	Ni-Cr-Mo alloy / UNS N06022
Finish	electropolished and passivated	electropolished and passivated
Seat	PCTFE (Polyimide optional)	PCTFE

**SHP option Ni-Cr-Mo alloy poppet and diaphragm only.
HF and HR option will not achieve rated outlet pressure at all inlet pressures.

All specifications subject to change without notice.

SERVICE AND SUPPORT BEYOND COMPARE

DIMENSIONAL INFORMATION

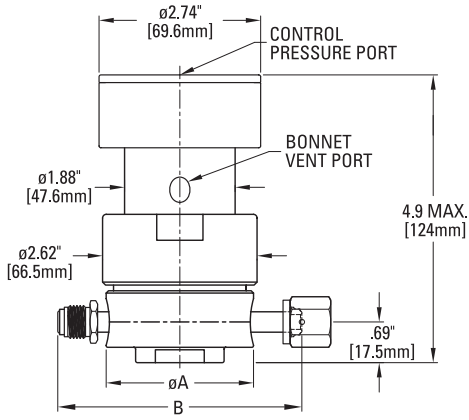

Face Seal	A	B
1/4" Male	2.00" (51 mm)	4.00" ±.02 (102 mm)
1/4" Female	2.00" (51 mm)	3.70" ±.02 (94 mm)
3/8"	2.50" (64 mm)	5.22" ±.03 (133 mm)
1/2"	2.50" (64 mm)	5.22" ±.03 (133 mm)
3/4"	2.50" (64 mm)	6.26" ±.04 (159 mm)

All dimensions in inches (mm). Metric dimensions are for reference only.

PORTING CONFIGURATIONS

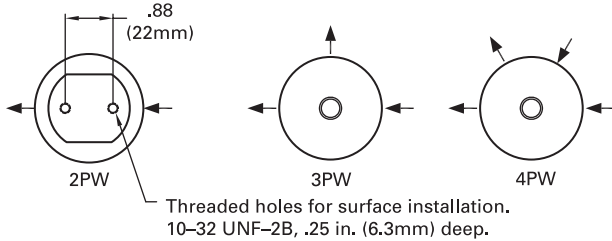

CAUTION: Product selection is the sole responsibility of the user, regardless of any recommendations or suggestions made by the factory. The user shall make selections based upon their own analysis and testing with regard to function, material compatibility and product ratings. Proper installation, operation and maintenance are also required to assure safe, trouble free performance.

ORDERING INFORMATION

Sample Order Number		AP 12PASM 3PW FV8 FV8 1 HF	
AP 12PA Series	AP 12PA = 7-150 psig (.5 to 10 bar)		
S Material	S = Stainless steel (SS) SH = SS/Ni-Cr-Mo alloy internals SHP = SS/Ni-Cr-Mo alloy poppet and diaphragm		
M Surface Finish Options	M = 10 µin. Ra max V = 7 µin. Ra max X = 5 µin. Ra max		
3PW Ports	2PW = 2 ports butt weld face seal 3PW = 3 ports butt weld face seal 4PW = 4 ports butt weld face seal		
FV8 FV8 Connections Inlet / Outlet	FV4 = 1/4 inch face seal female MV4 = 1/4 inch face seal male FV6 = 3/8 inch face seal female MV6 = 3/8 inch face seal male FV8 = 1/2 inch face seal female MV8 = 1/2 inch face seal male FV12 = 3/4 inch face seal female* MV12 = 3/4 inch face seal male*		
1 Gauges Source / Delivery	0 = No gauge V3 = 30-0-30 psig/bar L = 30-0-60 psig/bar 1 = 30-0-100 psig/bar 2 = 0-200 psig/bar 4 = 0-400 psig/bar 10 = 0-1000 psig/bar 40 = 0-4000 psig/bar H = 30-0-160 psig/bar		
HF Options	HR = High Inlet Pressure** HF = High Flow** VS = Polyimide seat SC = Short bonnet		

AP Tech has product options and variations which are not documented in data sheets. If you have a model number that is not defined by the ordering information, please consult the factory or your local representative.

