



SERIES AZ 1200

SINGLE STAGE REGULATOR

TIED DIAPHRAGM DESIGN

Flow Rates to 1,500 SLPM (52 scfm)

- SS 316L construction
- High performance
- 10 μ m. surface finish (25 μ m. optional)
- High flow with low particle generation
- Flow rates
 - standard to 800 slpm (28 scfm)
 - HF option to 1,000 slpm (35 scfm)
 - FC option to 1,500 slpm (52 scfm)
- Point of use or cylinder specialty and bulk gases
- Vacuum to 1,700 psig (117 bar) inlet
 - FC Option – vacuum to 300 psig (21 bar)
 - HR Option – vacuum to 3,000 psig (207 bar)
- Knob LOTO
- Installation and operating instructions available at www.aptech-online.com

Operating Parameters

Source pressure	AZ 1200	vacuum to 1,700 psig (117 bar)
	AZ 1200 HR	vacuum to 3,000 psig (207 bar)
	AZ 1200 FC	vacuum to 300 psig (21 bar)
Delivery pressure	AZ 1202	1 to 30 psig (0.07 to 2 bar) (not available for FC or HR)
	AZ 1206	2 to 60 psig (0.14 to 4 bar) (not available for FC or HR)
	AZ 1210	2 to 100 psig (0.14 to 7 bar)
	AZ 1215*	5 to 150 psig (0.34 to 10 bar)
	AZ 1225	preset to 250 psig (17 bar) at 800 psig inlet (not available for FC)
Proof pressure		150% of operating pressures
Burst pressure		300% of operating pressures

*AZ 1215 will not achieve full outlet pressure rating at all inlet pressures.

Other Parameters

Inlet/outlet connectors	1/4, 3/8, 1/2 inch face seal or tube weld
Flow coefficient (Cv) [‡]	0.9 (FC = 0.65, HF = 1.1)
Internal volume	1.07 in ³ (17.6 cm ³)
Operating temperature	-40° to +160°F (-40° to +71°C)**
Surface finish	10 μ m. (0.25 μ m) Ra avg. standard 25 μ m. (0.62 μ m) Ra avg. optional
Inboard leakage	2 x 10 ⁻¹⁰ sccs
Outboard leakage	2 x 10 ⁻⁹ sccs He
Leakage across seat	4 x 10 ⁻⁸ sccs He
Installation	surface or panel (optional)
Supply pressure effect	3.5 psig per 100 psig source pressure change
HF & FC	4.2 psig per 100 psig source pressure change

**VS option 14° to 194°F (-10° to +90°C).

[‡]A pressure regulator Cv is a nominal value which indicates the point of choked flow. Please refer to a flow curve or a recommendation guide for usable flow range.

Materials

	Series AZ 1200 S	Series AZ 1200 SHP
Wetted Parts		
Body, nozzle	stainless steel 316L***	stainless steel 316L***
Poppet	stainless steel 316L	Ni-Cr-Mo alloy / UNS N06022
Diaphragm	Ni-Cr-Mo alloy / UNS N06022	Ni-Cr-Mo alloy / UNS N06022
Finish	electropolished and passivated	electropolished and passivated
Seat	PCTFE (Polyimide optional)	PCTFE

All specifications subject to change without notice.

***Please refer to product note PN 414 regarding single melt 316L SS material.

SERVICE AND SUPPORT BEYOND COMPARE

DIMENSIONAL INFORMATION

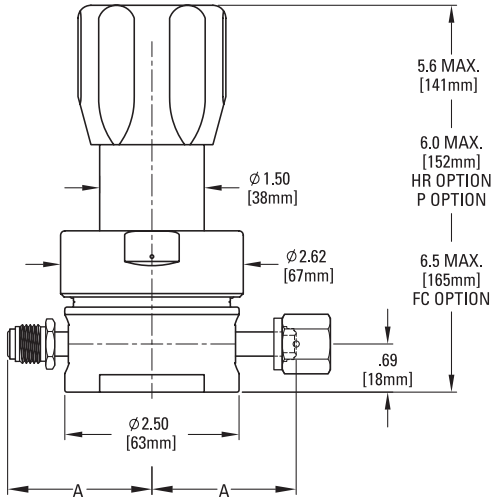

All dimensions in inches. Metric dimensions (mm) are for reference only.

Face Seal	A	
	in	mm
1/4"	2.15 ±.01	55
3/8", 1/2"	2.61 ±.02	66

PORTING CONFIGURATIONS

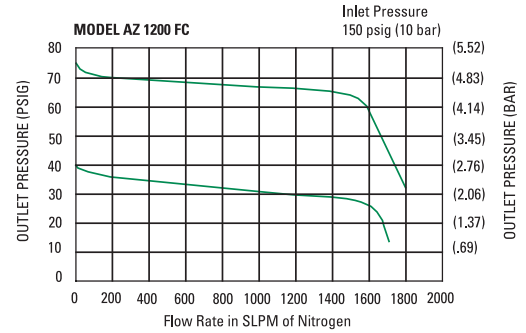
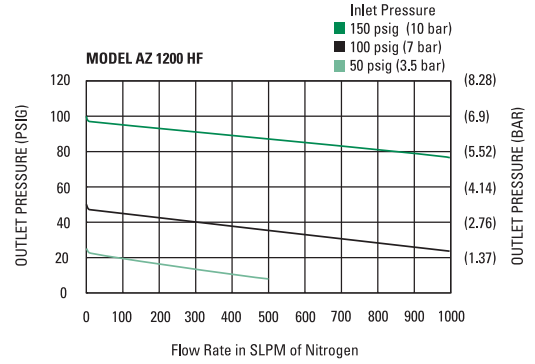
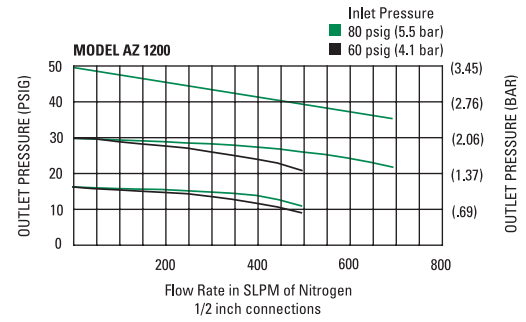
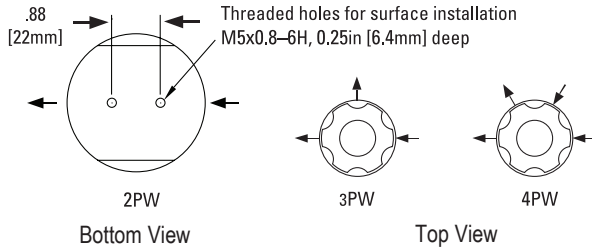

CAUTION: Product selection is the sole responsibility of the user, regardless of any recommendations or suggestions made by the factory. The user shall make selections based upon their own analysis and testing with regard to function, material compatibility and product ratings. Proper installation, operation and maintenance are also required to assure safe, trouble free performance.

ORDERING INFORMATION

Sample Order Number	AZ 1210SQ 3PW FV8 FV8 V3 FC
AZ 1210 Series	AZ 1202 = 1-30 psig (.07 to 2 bar) AZ 1206 = 2-60 psig (.14 to 4 bar) AZ 1210 = 2-100 psig (.14 to 7 bar) AZ 1215 = 5-150 psig (.34 to 10 bar) AZ 1225 = 250 psig (17 bar) preset
S Material	S = Stainless steel (SS) SHP = SS/Ni-Cr-Mo alloy poppet and diaphragm
Q Surface Finish Option	Q = 25 µin. Ra avg.
3PW Ports	2PW = 2 ports butt weld 3PW = 3 ports butt weld 4PW = 4 ports butt weld

FV8 FV8 | Connections Inlet / Outlet

Tube weld stub available.
"FC" option only available with 1/2" connectors.

- FV4 = 1/4 inch face seal female
- MV4 = 1/4 inch face seal male
- FV6 = 3/8 inch face seal female
- MV6 = 3/8 inch face seal male
- FV8 = 1/2 inch face seal female
- MV8 = 1/2 inch face seal male

V3 | Delivery Gauge*

*Standard gauge port is 1/4 inch face seal male (1/4 inch female available).

- 0 = No gauge
- V3 = 30-0-30 psig/bar
- L = 30-0-60 psig/bar
- 1 = 0-100 psig/bar
- H = 30-0-160 psig/bar
- 4 = 0-400 psig/bar
- 10 = 0-1000 psig/bar
- 40 = 0-4000 psig/bar

FC | Options

**HR, HF and FC options are only available separately. These options may not be combined.
***Panel hole 1.56" diameter.

- VS = Polyimide seat
- HR = High Inlet Pressure**
- HF = High Flow**
- FC = Force Compensation**
- P = Panel installation***
- KL = Knob LOTO
(refer to AP KL data sheet)

AP Tech has product options and variations which are not documented in data sheets. If you have a model number that is not defined by the ordering information, please consult the factory or your local representative.