



SERIES AP 4141, 4150 & 4157

1/2 INCH DIAPHRAGM VALVE
Springless – manual and pneumatic (NC)

- 316L VAR SS secondary remelt construction
- Flow capacity 0.8 C_v
- Operating pressure vacuum to 250 psig (17 bar)
- Surface finish
15 Ra max/10 Ra avg
(10, 7 & 5 Ra max optional)
- LOTO—standard 4157
- Machined from bar stock
- Springless design for UHP gas service
- AP 4141 pneumatic NC
- AP 4150 manual knob
1/4 turn with open/close indicator
- AP 4157 manual knob
1/4 turn pull to open with LOTO
- Installation and operating instructions available at www.aptech-online.com

Operating Parameters

Inlet pressure	vacuum to 250 psig (17 bar)
Outlet pressure	vacuum to inlet pressure
Proof pressure	150% of operating pressure
Burst pressure	300% of operating pressure

Other Parameters

Inlet/outlet connectors	1/4 and 1/2 inch face seal, or 3/8 and 1/2 inch tube stub
Flow coefficient (C _v)*	0.8, X _T = 0.7
Internal volume	0.37 in ³ (6.1 cm ³)
Operating temperature	-40° to +160°F (-40° to +71°C)**
Surface finish	15 μin. Ra max/10 μin. Ra (0.4/0.25 μm) standard 10 μin (0.25 μm) and 7 μin (0.18 μm) Ra max optional Optional surface finishes meet or exceed 5 μin Ra average
Inboard leakage	2 x 10 ⁻¹⁰ sccs
Outboard leakage	2 x 10 ⁻⁹ sccs He
Leakage across seat	1 x 10 ⁻⁹ sccs He

*C_v based upon 1/2 inch fittings.

**VS option 14° to 194°F (-10° to + 90°C).

Operating Parameters – pneumatic valve

Status AP 4141	normally closed (NC)
Actuation port	M5, side port
Actuation pressure	70 to 110 psig (4.8 to 7.6 bar)

Materials

Wetted Parts	Series AP 4141 & AP 4150
Body	SS 316L secondary remelt
Finish	electropolished and passivated
Diaphragm	Co-Ni-Cr alloy / UNS R30003
Seat	PCTFE (Polyimide optional)

All specifications subject to change without notice.

SERVICE AND SUPPORT BEYOND COMPARE

DIMENSIONAL INFORMATION

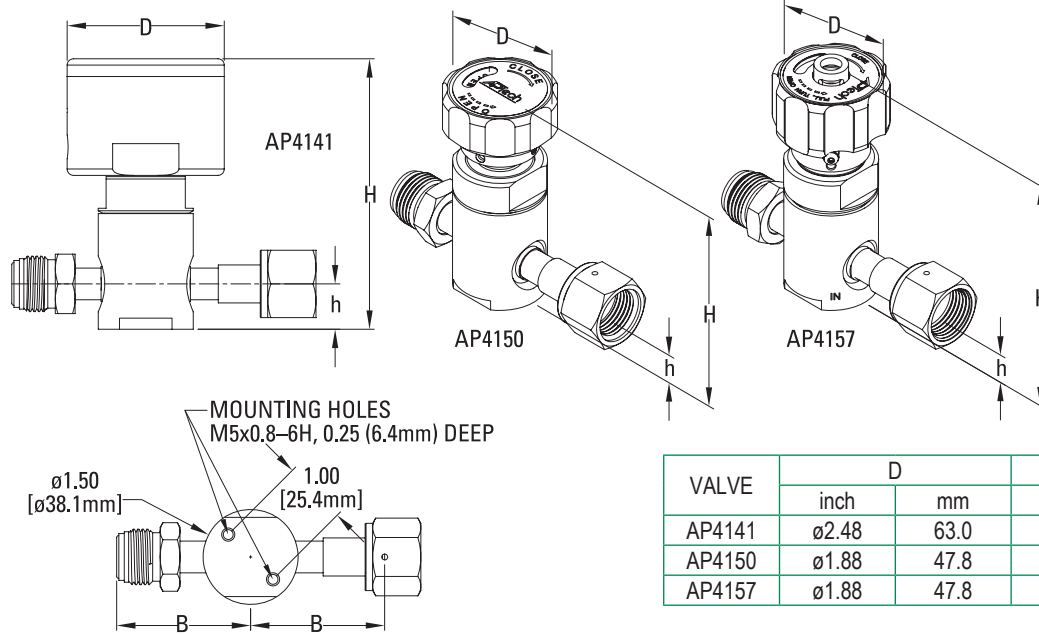

VALVE	D		H	
	inch	mm	inch	mm
AP4141	ø2.48	63.0	4.3	109.2
AP4150	ø1.88	47.8	3.8	96.5
AP4157	ø1.88	47.8	4.3	109.5

CONNECTION	B		h	
	inch	mm	inch	mm
FV4, MV4	1.59±.02	40.4	0.715	18.2
FV8, MV8	2.12±.02	53.8	0.715	18.2
TW6	1.49±.02	37.8	0.715	18.2
TW8	1.53±.02	38.9	0.715	18.2

- Metric dimensions are for reference only.
- Height of the valve (H) is an approximate value.
- All specifications subject to change without notice.
- Manual valve is shown in open position.

PORTING CONFIGURATIONS

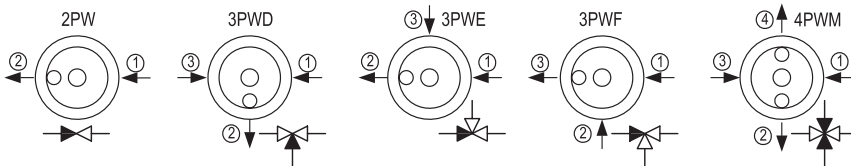

CAUTION: Product selection is the sole responsibility of the user, regardless of any recommendations or suggestions made by the factory. The user shall make selections based upon their own analysis and testing with regard to function, material compatibility and product ratings. Proper installation, operation and maintenance are also required to assure safe, trouble free performance.

ORDERING INFORMATION

Sample Order Number		AP 4141SM 2PW MV8 MV8 VS	
AP 4141 Series	AP 4141 AP 4150 AP 4157	MV8 MV8 Connections Inlet / Outlet	FV4 = 1/4 inch face seal female MV4 = 1/4 inch face seal male TW6 = 3/8 inch tube weld stub FV8 = 1/2 inch face seal female MV8 = 1/2 inch face seal male TW8 = 1/2 inch tube weld stub
S Material	S = Stainless steel (SS)	vs Options	VS = Polyimide seat SC = Short bonnet ISH = Indicating switch, 4150 only IPC = Indicating switch, NC, 4141 only IPO = Indicating switch, NO, 4141 only
M Surface Finish Option	M = 10 µin. Ra max V = 7 µin. Ra max X = 5 µin. Ra max		
2PW Ports	2PW = 2 ports 3PWD = 3 ports 3PWF = 3 ports		

AP Tech has product options and variations which are not documented in data sheets. If you have a model number that is not defined by the ordering information, please consult the factory or your local representative.